

# A - A

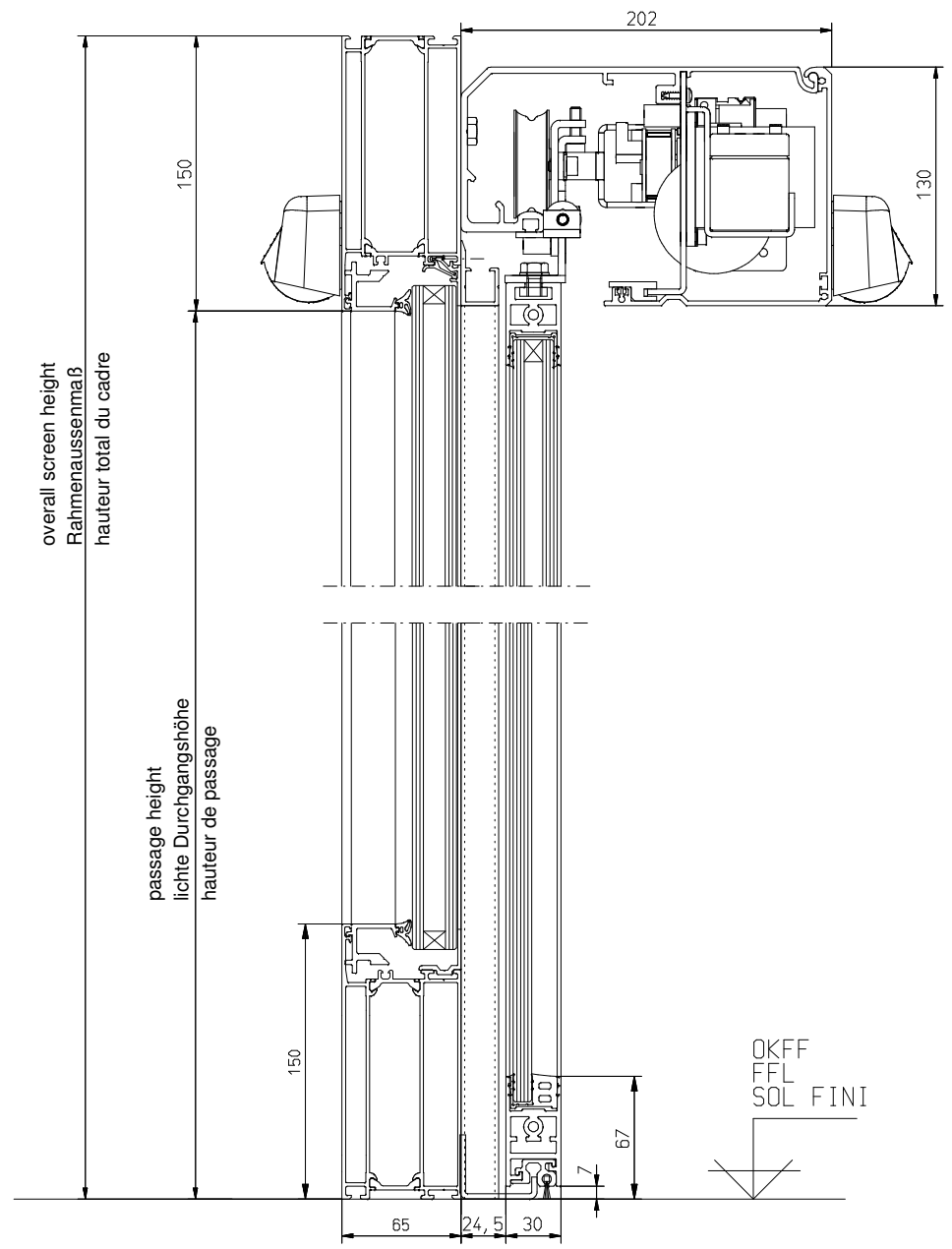

front view  
Ansicht Aussen  
vue de face

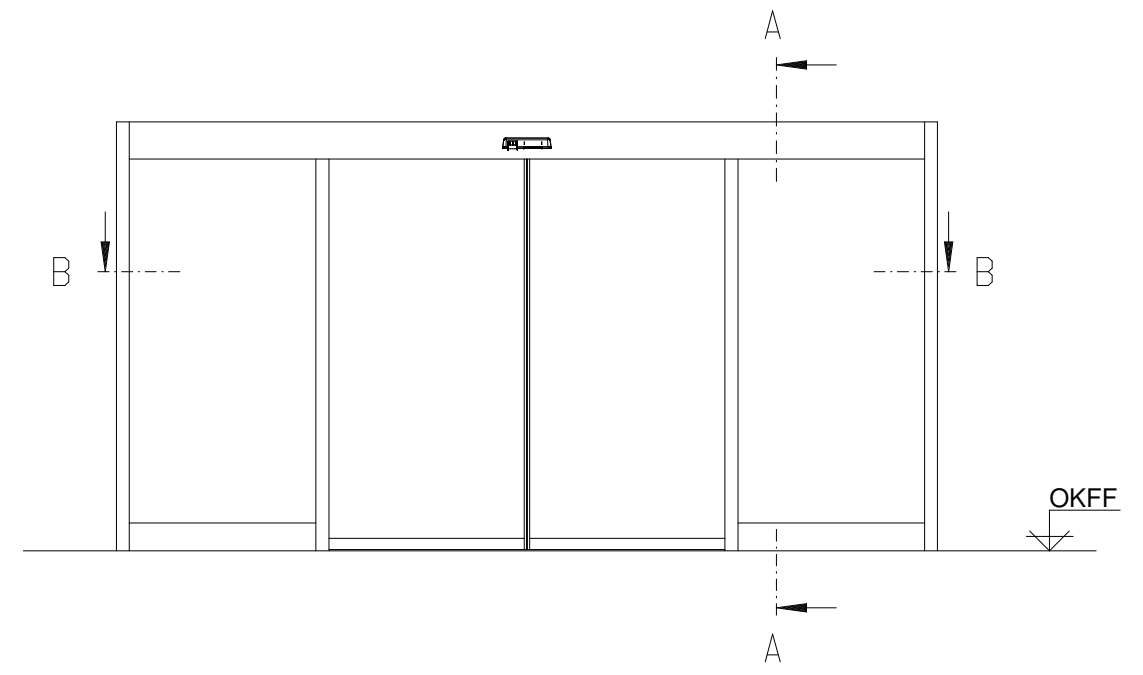

# B - B

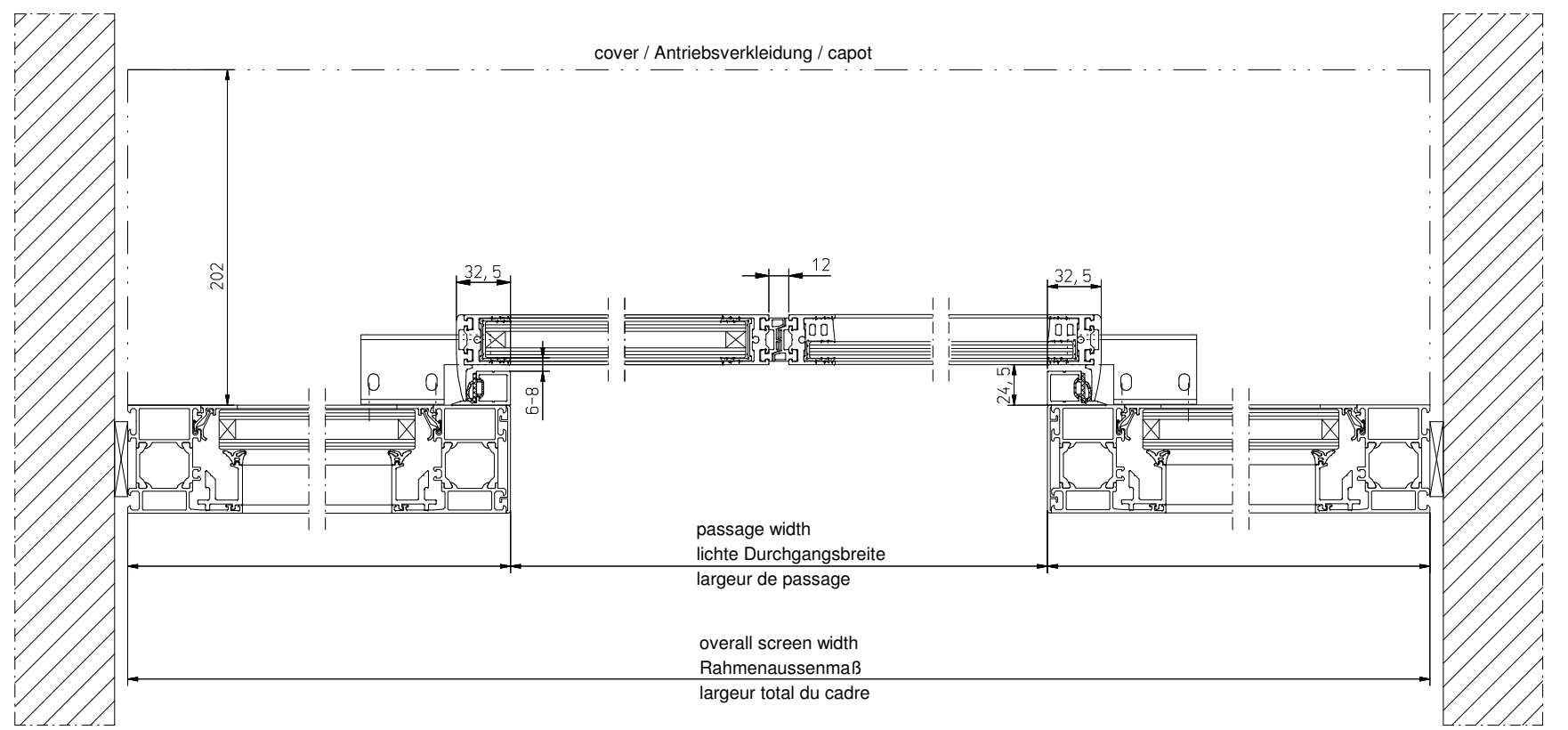

	<i>Datum</i>		<i>Benennung</i>
<i>Bearb.</i>	12.07.2011	Johannpa.	
<i>Gepr.</i>			EM / EM-F -Profilsystem Schüco 2 flügelig -Profile system Schüco 2 door leaves -Porte à 2 vantaux avec profils Schüco
<i>Norm</i>			<i>Zeichnung - Nr.</i>
			A-9902090 EM-2 EL ST
GU Automatic GmbH www.g-u.com			Änderungen vorbehalten